

Line Blind Valves

Double Block and Bleed
Cargo Segregation

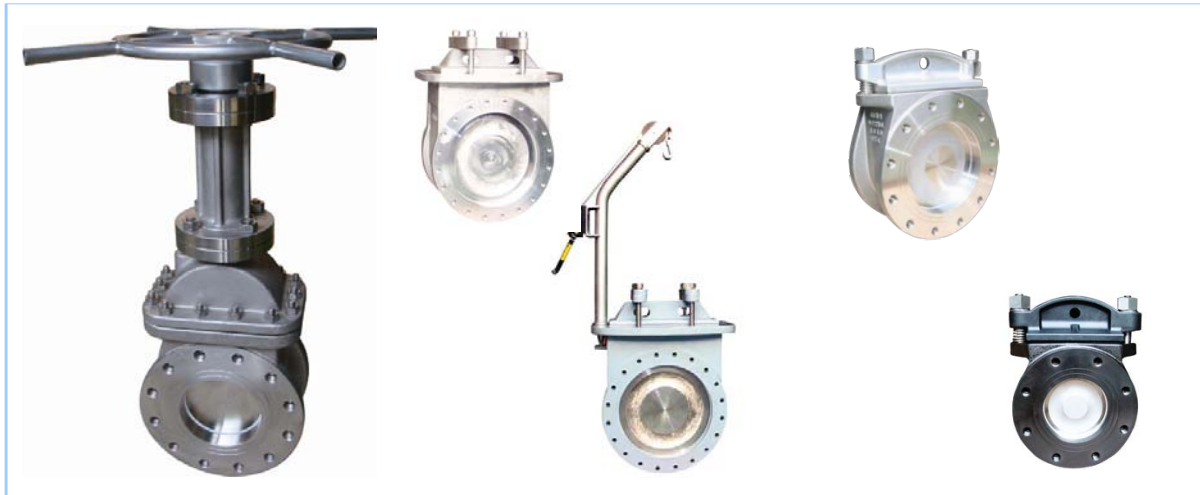

API 607
Fire Safe
Certified



New Innovative
Patented Design



Introduction

Easy to operate and reliable in use.

Applications

Crude oil product (Tankers)
Chemical Tankers. LPG and LNG carriers.
Rigs. Refineries. Terminals.
Chemical and Petrochemical industries.

Wherever you require security When blinding

Chemicals. Oils. Solvents. Gases.
Water. (Steam saturated).

The design meets the requirements of

Full segregation between different fluids.	Quality product.
Double shut off (DBB).	Simple and efficient design.
Safety against incorrect operation.	Small overall dimensions.
Drainage of valve body (DBB).	Full flow.
Visual inspection	



**LINE
BLIND
VALVES**

improved
top quality 100% tight

VALVE OPEN

Top cover in position and
valve discs removed.
FREE FLOW

VALVE CLOSED

Valve discs in position
cover plates removed.
100% TIGHT

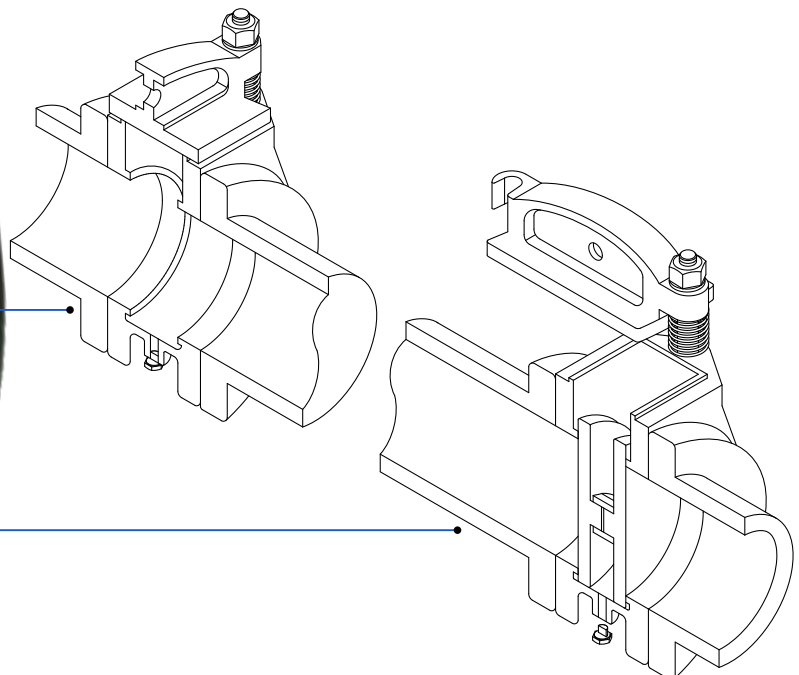

Line Blind Valve Models, Figure Numbers and Features

Figure 5400



The Classic Double Block & Bleed Line Blind Valve

1. Easy operation, trouble-free service. When closed no liquid or gas can leak to the opposite side, up- and downstream fluids are fully segregated (Double Block & Bleed).
2. One person can operate 2"~12" valves, 2 people can operate the larger sizes 14"~22".
3. Simple and solid construction requires minimum maintenance.
4. Short face to face length.
5. Several Flange Standards available, ANSI/ASME, DIN, JIS, etc.
6. When the valve is closed the top cover can be removed to inspect the valve's body cavity for possible leakage (Double Block. & Bleed)
7. Plug in cavity bottom to bleed out leaked fluid.

Figure 5410



Double Block & Bleed Expanding Gate Valve

1. Quick operation, trouble-free service. When closed no liquid or gas can leak to the opposite side, up- and downstream fluids are fully segregated (Double Block & Bleed).
2. Simple and solid construction requires minimum maintenance.
3. Several Flange Standards available, ANSI/ASME, DIN, JIS, etc.
4. Easy to operate, no contact with the pipeline fluids, internals do not have to be removed when opening the valve.
5. Only one person needed to operate, saves time and energy
6. No tools required to operate the valve, just turn the handwheel to open/close the valve
7. When the valve is closed the valve cavity can be inspected, by removing the drain plug, for possible leakage (Double Block. & Bleed)
8. Plug in cavity bottom to bleed out leaked fluid.

Figure 5420



Double Block & Bleed Expanding Gate Valve with Automatic Bleed System

As Figure 5410 however with automatic bleed system.

1. Cavity Bleed opens automatically when valve is closed and closes automatically when valve opens

Figure 5430



The New Innovative Design Double Block & Bleed Line Blind Valve

As Figure 5400 however with special device to quickly remove the valve internals

1. Quick and easy removal of the valve internals

Document : LBV
 Revision : 0
 Year : 2009

Line Blind Valves

Double Block and Bleed
 Cargo Segregation



Figure 5400

Size
 DN50~DN300(2"~12")
 Pressure class
 DIN PN10 / 16 / 25 / 40
 JIS 10K / 16K / 20K / 30K
 ANSI 150LBS

DNV TYPE APPROVED

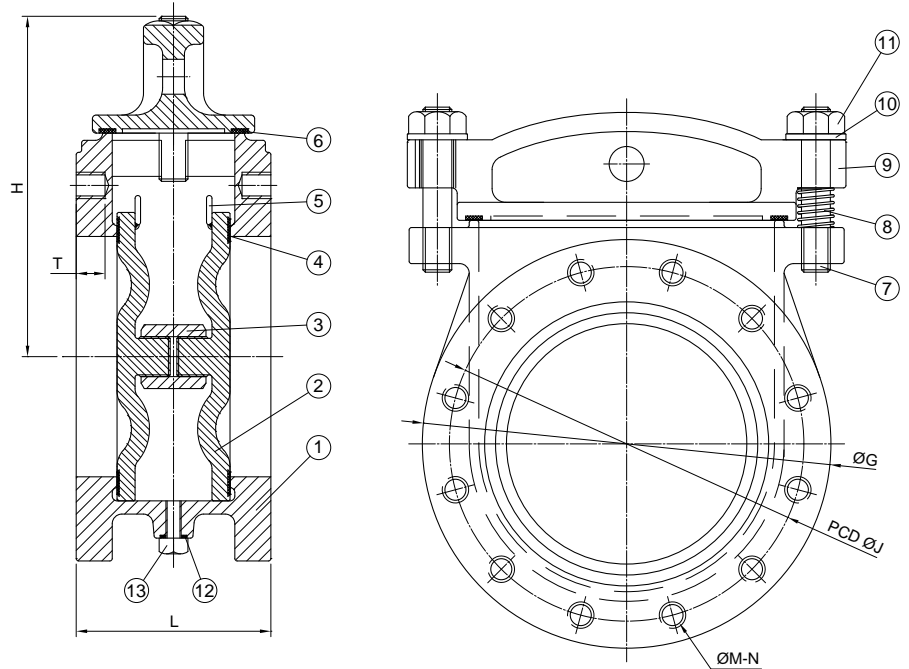

MATERIALS LIST

NO.	PART NAME	TYPE S.S.	TYPE C.S.
1	BODY	A351 Gr.CF8M(MoMin 2.75%)	A216 Gr.WCB
2	DISC	A351 Gr.CF8M(MoMin 2.75%)	AISI 304
3	TIGHTENING NUT	A351 Gr.CF8M(MoMin 2.75%)	AISI 304
4	DISC SEAL	PTFE	PTFE
5	STOP PIN	AISI 316	AISI 304
6	TOP COVER SEAL	KEMFLON+PTFE	KEMFLON+PTFE
7	TOP COVER BOLTS	AISI 316	AISI 304
8	SPRING	STAINLESS STEEL	STAINLESS STEEL
9	TOP COVER	A351 Gr.CF8M(MoMin 2.75%)	A216 Gr.WCB
10	WASHER	AISI 316	AISI 304
11	TOP COVER NUT	AISI 316	AISI 304
12	DRAIN PLUG SEAL	PTFE	PTFE
13	DRAIN PLUG	AISI 316	AISI 304

S.S. Stainless Steel(MoMin 2.75%) C.S. Cast Steel(GS-C25)

Line Blind Valves

Double Block and Bleed
Cargo Segregation



Figure 5400

PART LIST

NO.	PART NAME
1	BODY
2	DISC
3	TIGHTENING NUT
4	DISC SEAL
5	STOP PIN
6	TOP COVER SEAL
7	TOP COVER BOLTS
8	SPRING
9	TOP COVER
10	WASHER
11	TOP COVER NUT
12	DRAIN PLUG SEAL
13	DRAIN PLUG

DIMENSIONS

Unit:mm

SIZE	øG	H	øJ	L	øM	N	T	
2"	PN 10	165.0	173.0	125.0	154.0	M16	4	18.0
	PN 16	165.0	173.0	125.0	154.0	M16	4	18.0
	PN 25	165.0	173.0	125.0	154.0	M16	4	18.0
	PN 40	165.0	173.0	125.0	154.0	M16	4	18.0
2-1/2"	PN 10	185.0	185.0	145.0	154.0	M16	4	18.0
	PN 16	185.0	185.0	145.0	154.0	M16	4	18.0
	PN 25	185.0	185.0	145.0	154.0	M16	8	18.0
3"	PN 10	200.0	194.0	160.0	154.0	M16	8	18.0
	PN 16	200.0	194.0	160.0	154.0	M16	8	18.0
	PN 25	200.0	194.0	160.0	154.0	M16	8	18.0
4"	PN 10	220.0	235.0	180.0	162.0	M16	8	20.0
	PN 16	220.0	235.0	180.0	162.0	M16	8	20.0
	PN 25	235.0	235.0	190.0	162.0	M20	8	20.0
5"	PN 10	250.0	245.0	210.0	162.0	M16	8	22.0
	PN 16	250.0	245.0	210.0	162.0	M16	8	22.0
	PN 25	270.0	245.0	220.0	162.0	M24	8	22.0
6"	PN 10	285.0	265.0	240.0	162.0	M20	8	22.0
	PN 16	285.0	265.0	240.0	162.0	M20	8	22.0
	PN 25	300.0	265.0	250.0	162.0	M24	8	22.0
8"	PN 10	340.0	300.0	295.0	162.0	M20	8	24.0
	PN 16	340.0	300.0	295.0	162.0	M20	12	24.0
	PN 25	360.0	300.0	310.0	162.0	M24	12	24.0
10"	PN 10	395.0	330.0	350.0	200.0	M20	12	26.0
	PN 16	405.0	330.0	355.0	200.0	M24	12	26.0
	PN 25	425.0	330.0	370.0	200.0	M27	12	26.0
12"	PN 10	445.0	360.0	400.0	200.0	M20	12	28.0
	PN 16	460.0	360.0	410.0	200.0	M24	12	28.0
	PN 25	485.0	360.0	430.0	200.0	M27	16	28.0
PN 40	515.0	360.0	450.0	200.0	M30	16	28.0	

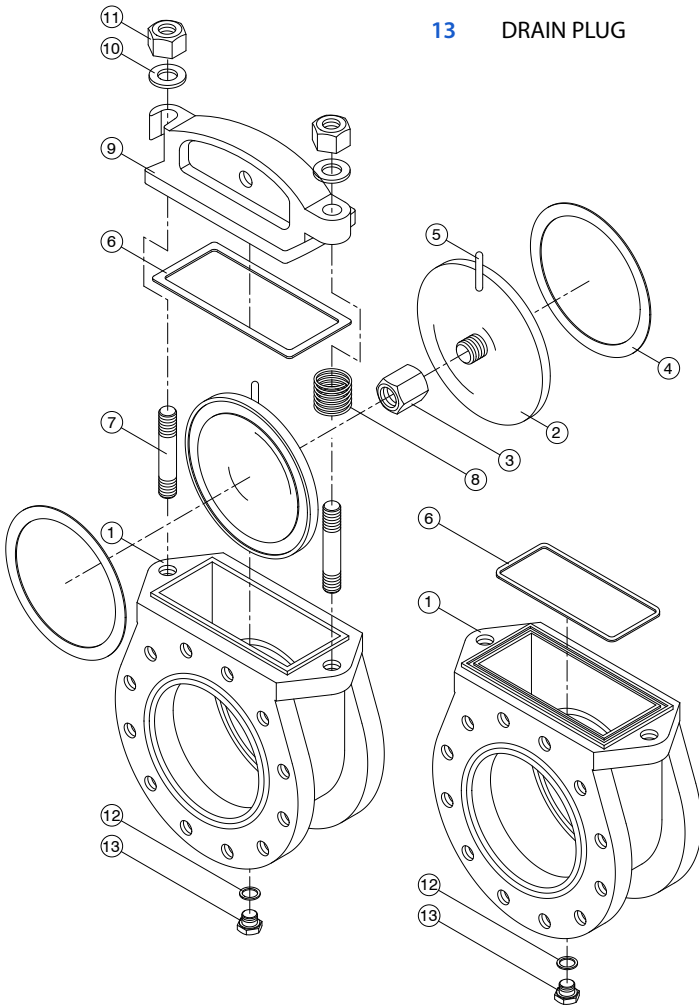

2" - 8"

10" - 12"

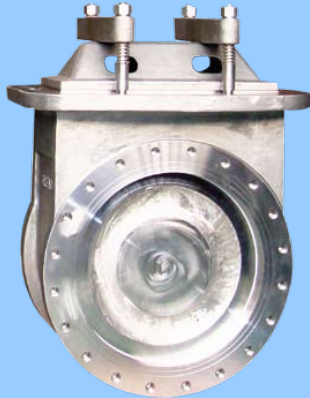
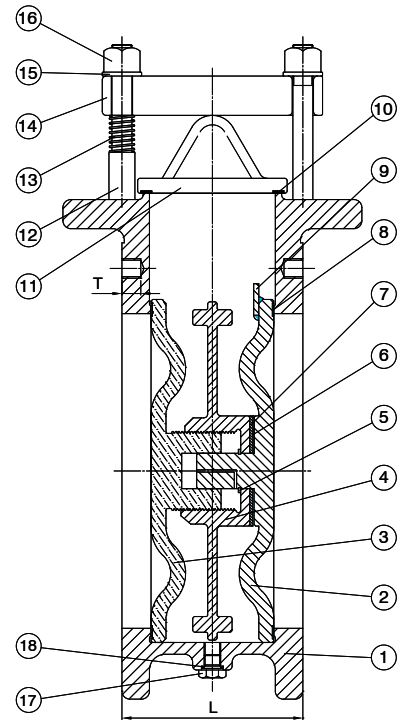
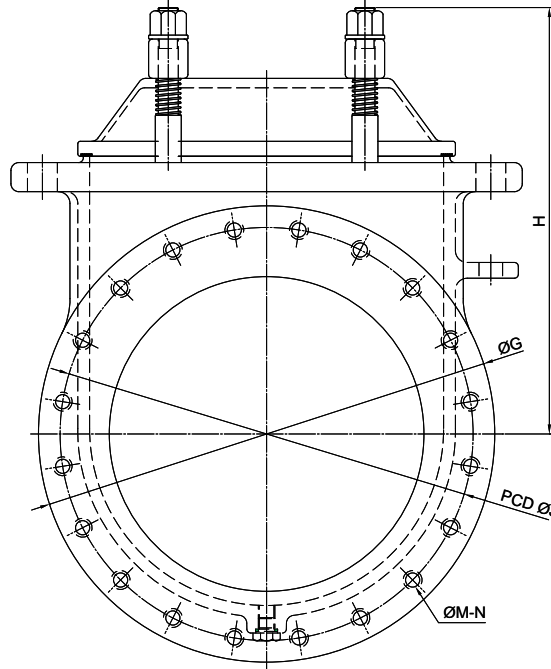

Figure 5400

Size
 DN350~DN750(14"~30")
 Pressure class
 DIN PN10 / 16 / 25 / 40
 JIS 10K / 16K / 20K / 30K
 ANSI 150LBS



MATERIALS LIST

NO.	PART NAME	TYPE S.S.	TYPE C.S.
1	BODY	A351 Gr.CF8M(MoMin 2.75%)	A216 Gr.WCB
2	DISC-BOLT	A351 Gr.CF8M(MoMin 2.75%)	AISI 304
3	DISC-ROD	A351 Gr.CF8M(MoMin 2.75%)	AISI 304
4	TIGHTENING-DISC	A351 Gr.CF8M(MoMin 2.75%)	AISI 304
5	SEEGER-RING	AISI 316	AISI 316
6	FRICTION WASHER	PTFE	PTFE
7	PRESSURE WASHER	BRONZE	BRONZE
8	DISC SEAL	PTFE	PTFE
9	STOPPER	AISI 316	AISI 304
10	TOP COVER SEAL	KEMFLON+PTFE	KEMFLON+PTFE
11	TOP COVER	A351 Gr.CF8M(MoMin 2.75%)	A216 Gr.WCB
12	TOP COVER BOLTS	AISI 316	AISI 304
13	SPRING	STAINLESS STEEL	STAINLESS STEEL
14	COVER -BAR	A351 Gr.CF8M(MoMin 2.75%)	A216 Gr.WCB
15	WASHER	AISI 316	AISI 304
16	TOP COVER NUT	AISI 316	AISI 304
17	DRAIN PLUG	AISI 316	AISI 304
18	DRAIN PLUG SEAL	PTFE	PTFE

S.S. Stainless Steel(MoMin 2.75%) | C.S. Cast Steel(GS-C25)



DIMENSIONS

Unit:mm

SIZE		øG	H	øJ	L	øM	N	T
14"	PN 10	505.0	505.0	460.0	230.0	M20	16	23.0
	PN 16	520.0	505.0	470.0	230.0	M24	16	23.0
16"	PN 10	565.0	540.0	515.0	230.0	M24	16	24.0
	PN 16	580.0	540.0	525.0	230.0	M27	16	24.0
18"	PN 10	615.0	602.5	565.0	260.0	M24	20	26.0
	PN 16	640.0	602.5	585.0	260.0	M27	20	26.0
20"	PN 10	670.0	645.0	620.0	272.0	M24	20	28.0
	PN 16	715.0	645.0	650.0	272.0	M30	20	28.0
22"	PN 10	730.0	703.0	675.0	350.0	M27	20	30.0
	PN 16	775.0	703.0	710.0	350.0	M30	20	30.0

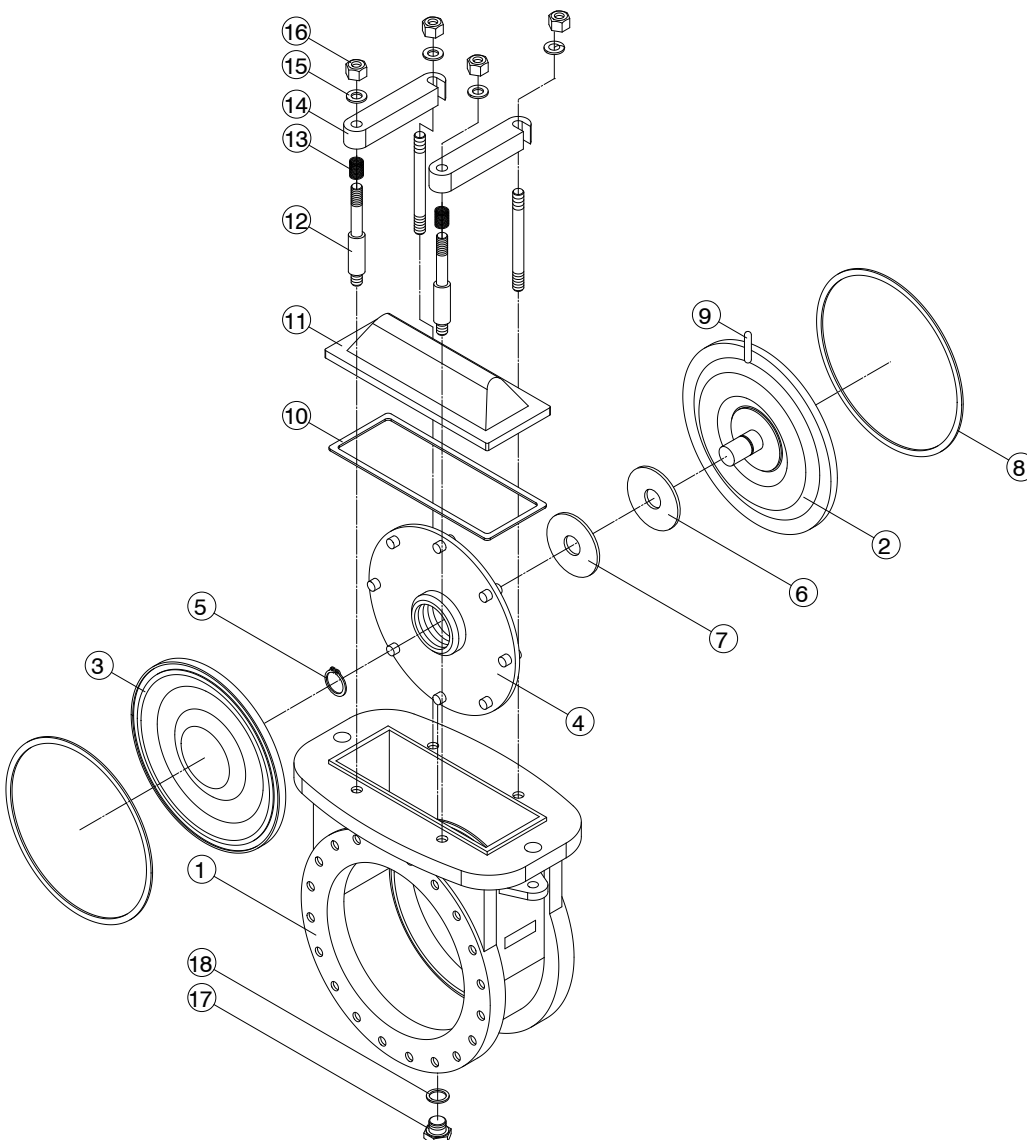

PART LIST

NO.	PART NAME
1	BODY
2	DISC-BOLT
3	DISC-ROD
4	TIGHTENING-DISC
5	SEEGER-RING
6	FRICTION-DISC
7	PRESSURE-DISC
8	DISC SEAL
9	STOPPER
10	TOP COVER SEAL
11	TOP COVER
12	TOP COVER BOLTS
13	SPRING
14	COVER-BAR
15	WASHER
16	TOP COVER NUT
17	DRAIN PLUG
18	DRAIN PLUG SEAL

Line Blind Valves

Double Block and Bleed
Cargo Segregation



Size
DN50-DN300(2"~12")
Pressure class
DIN PN10 / 16 / 25 / 40
JIS 10K / 16K / 20K / 30K
ANSI 150LBS

Figure 5410

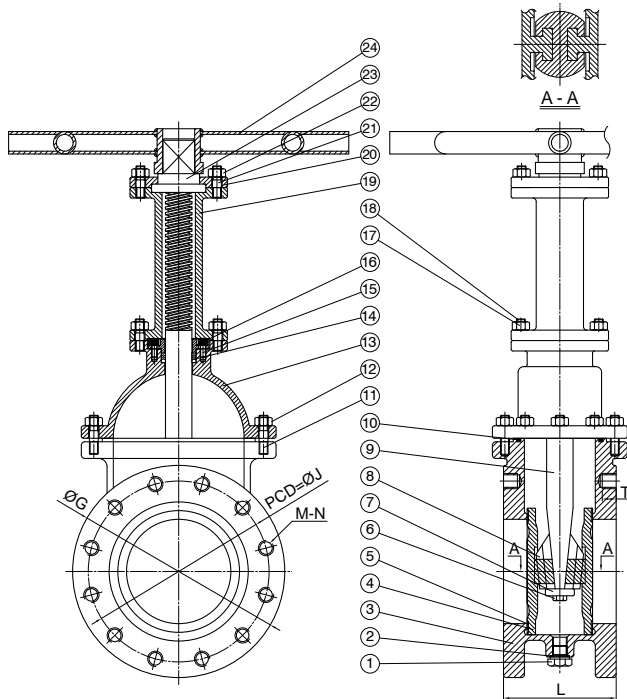

DIMENSIONS

Unit:mm

SIZE	øG	øJ	L	øM	N	T	
2"	PN 10	165.0	125.0	154.0	M16	4	18.0
	PN 16	165.0	125.0	154.0	M16	4	18.0
	PN 25	165.0	125.0	154.0	M16	4	18.0
2-1/2"	PN 10	185.0	145.0	154.0	M16	4	18.0
	PN 16	185.0	145.0	154.0	M16	4	18.0
	PN 25	185.0	145.0	154.0	M16	8	18.0
3"	PN 10	200.0	160.0	154.0	M16	8	18.0
	PN 16	200.0	160.0	154.0	M16	8	18.0
	PN 25	200.0	160.0	154.0	M16	8	18.0
4"	PN 10	220.0	180.0	162.0	M16	8	20.0
	PN 16	220.0	180.0	162.0	M16	8	20.0
	PN 25	235.0	190.0	162.0	M20	8	20.0
5"	PN 10	250.0	210.0	162.0	M16	8	22.0
	PN 16	250.0	210.0	162.0	M16	8	22.0
	PN 25	270.0	220.0	162.0	M24	8	22.0
6"	PN 10	285.0	240.0	162.0	M20	8	22.0
	PN 16	285.0	240.0	162.0	M20	8	22.0
	PN 25	300.0	250.0	162.0	M24	8	22.0
8"	PN 10	340.0	295.0	162.0	M20	8	24.0
	PN 16	340.0	295.0	162.0	M20	12	24.0
	PN 25	360.0	310.0	162.0	M24	12	24.0
10"	PN 10	395.0	350.0	200.0	M20	12	26.0
	PN 16	405.0	355.0	200.0	M24	12	26.0
	PN 10	425.0	370.0	200.0	M27	12	26.0
12"	PN 10	450.0	385.0	200.0	M30	12	26.0
	PN 10	445.0	400.0	200.0	M20	12	28.0
	PN 16	460.0	410.0	200.0	M24	12	28.0
PN 10	485.0	430.0	200.0	M27	16	28.0	
PN 40	515.0	450.0	200.0	M30	16	28.0	

MATERIALS LIST

NO.	PART NAME	TYPE S.S.	TYPE C.S.
1	DRAIN PLUG	AISI 316	AISI 304
2	DRAIN PLUG SEAL	PTFE	PTFE
3	BODY	A351 Gr.CF8M(MoMin 2.75%)	A216 Gr.WCB
4	DISC	A351 Gr.CF8M(MoMin 2.75%)	A216 Gr.WCB
5	DISC SEAL	PTFE	PTFE
6	BOLT	AISI 316	AISI 304
7	BRACKET	AISI 316	AISI 304
8	SLIDE	A351 Gr.CF8M(MoMin 2.75%)	A216 Gr.WCB
9	STEM	AISI 316	AISI 304
10	TOP COVER SEAL	PTFE	PTFE
11	TOP COVER STUD	AISI 316	AISI 304
12	TOP COVER NUT	AISI 316	AISI 304
13	TOP COVER	A351 Gr.CF8M(MoMin 2.75%)	A216 Gr.WCB
14	PACKING	PTFE	PTFE
15	GLAND BOLT	AISI 316	AISI 304
16	GLAND	AISI 316	AISI 304
17	BONNET NUT	AISI 316	AISI 304
18	BONNET STUD	AISI 316	AISI 304
19	BONNET	A351 Gr.CF8M(MoMin 2.75%)	A216 Gr.WCB
20	BRACKET	AISI 316	AISI 304
21	BRACKET STUD	AISI 316	AISI 304
22	BRACKET NUT	AISI 316	AISI 304
23	YOKE SLEEVE	BRONZE	BRONZE
24	HANDLE	STEEL	STEEL

S.S. Stainless Steel(MoMin 2.75%) | C.S. Cast Steel(GS-C25)

Document : LBV
 Revision : 0
 Year : 2009

Line Blind Valves

Double Block and Bleed
 Cargo Segregation

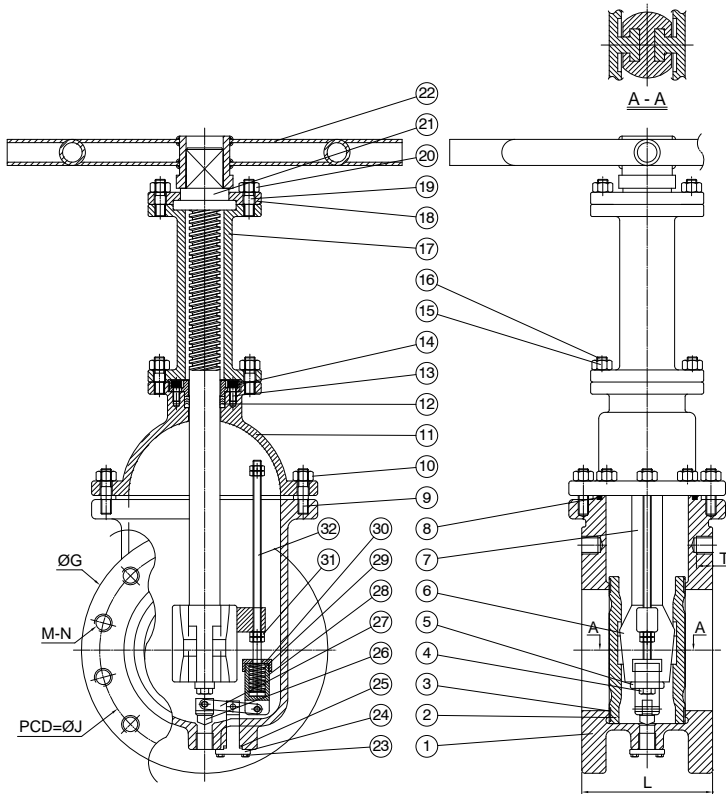

Size
 DN50~DN300(2"~12")
 Pressure class
 DIN PN10 / 16 / 25 / 40
 JIS 10K / 16K / 20K / 30K
 ANSI 150LBS



Figure 5420

DIMENSIONS

Unit:mm

SIZE	øG	øJ	L	øM	N	T	
2"	PN 10	165.0	125.0	154.0	M16	4	18.0
	PN 16	165.0	125.0	154.0	M16	4	18.0
	PN 25	165.0	125.0	154.0	M16	4	18.0
2-1/2"	PN 10	185.0	145.0	154.0	M16	4	18.0
	PN 16	185.0	145.0	154.0	M16	4	18.0
	PN 25	185.0	145.0	154.0	M16	8	18.0
3"	PN 10	200.0	160.0	154.0	M16	8	18.0
	PN 16	200.0	160.0	154.0	M16	8	18.0
	PN 25	200.0	160.0	154.0	M16	8	18.0
4"	PN 10	220.0	180.0	162.0	M16	8	20.0
	PN 16	220.0	180.0	162.0	M16	8	20.0
	PN 25	235.0	190.0	162.0	M20	8	20.0
5"	PN 10	250.0	210.0	162.0	M16	8	22.0
	PN 16	250.0	210.0	162.0	M16	8	22.0
	PN 25	270.0	220.0	162.0	M24	8	22.0
6"	PN 10	285.0	240.0	162.0	M20	8	22.0
	PN 16	285.0	240.0	162.0	M20	8	22.0
	PN 25	300.0	250.0	162.0	M24	8	22.0
8"	PN 10	340.0	295.0	162.0	M20	8	24.0
	PN 16	340.0	295.0	162.0	M20	12	24.0
	PN 25	360.0	310.0	162.0	M24	12	24.0
10"	PN 10	395.0	350.0	200.0	M20	12	26.0
	PN 16	405.0	355.0	200.0	M24	12	26.0
	PN 25	425.0	370.0	200.0	M27	12	26.0
12"	PN 10	445.0	400.0	200.0	M20	12	28.0
	PN 16	460.0	410.0	200.0	M24	12	28.0
	PN 25	485.0	430.0	200.0	M27	16	28.0
	PN 40	515.0	450.0	200.0	M30	16	28.0

MATERIALS LIST

NO.	PART NAME	TYPE S.S.	TYPE C.S.
1	BODY	A351 Gr.CF8M(MoMin 2.75%)	A216 Gr.WCB
2	DISC	A351 Gr.CF8M(MoMin 2.75%)	AISI 304
3	DISC SEAL	PTFE	PTFE
4	BOLT	AISI 316	AISI 304
5	BRACKET	AISI 316	AISI 304
6	SLIDE	AISI 316	AISI 304
7	STEM	AISI 316	AISI 304
8	TOP COVER SEAL	PTFE	PTFE
9	TOP COVER BOLT	AISI 316	AISI 304
10	TOP COVER NUT	AISI 316	AISI 304
11	TOP COVER	A351 Gr.CF8M(MoMin 2.75%)	A216 Gr.WCB
12	PACKING	PTFE	PTFE
13	GLAND BOLT	AISI 316	AISI 304
14	GLAND	AISI 316	AISI 304
15	BONNET NUT	AISI 316	AISI 304
16	BONNET BOLT	AISI 316	AISI 304
17	BONNET	A351 Gr.CF8M(MoMin 2.75%)	A216 Gr.WCB
18	BRACKET	AISI 316	AISI 304
19	BRACKET BOLT	AISI 316	AISI 304
20	BRACKET NUT	AISI 316	AISI 304
21	YOKE SLEEVE	BRONZE	BRONZE
22	HANDLE	STEEL	STEEL
23	BOLT	AISI 316	AISI 304
24	BOTTOM PIN	AISI 316	AISI 304
25	BOTTOM SEAL	PTFE	PTFE
26	PLUG	AISI 316	AISI 304
27	TRANSMITTAL BAR	AISI 316	AISI 304
28	SPRING BOX	AISI 316	AISI 304
29	SPRING	AISI 316	AISI 304
30	SPRING BOX COVER	AISI 316	AISI 304
31	NUT	AISI 316	AISI 304
32	STOP BAR	AISI 316	AISI 304

S.S. Stainless Steel(MoMin 2.75%) | C.S. Cast Steel(GS-C25)

Line Blind Valves

Double Block and Bleed
Cargo Segregation

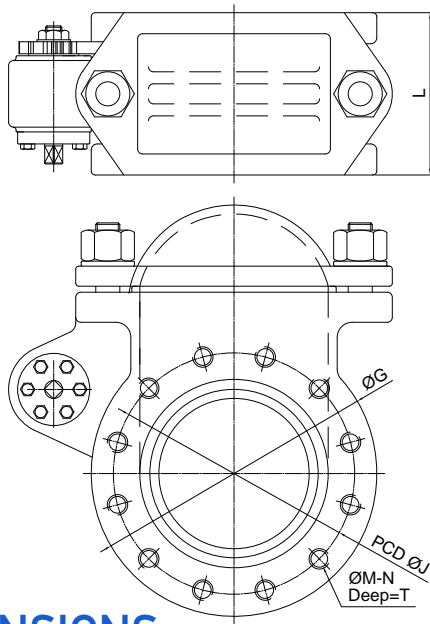

DIMENSIONS

Unit:mm

SIZE	øG	øJ	L	øM	N	T	
2"	JIS 10K	155.0	120.0	154.0	M16	4	16.0
	JIS 16K	155.0	120.0	154.0	M16	8	16.0
	JIS 20K	155.0	120.0	154.0	M16	8	16.0
2-1/2"	JIS 10K	175.0	140.0	154.0	M16	4	18.0
	JIS 16K	175.0	140.0	154.0	M16	8	18.0
	JIS 20K	175.0	140.0	154.0	M16	8	18.0
3"	JIS 10K	185.0	150.0	154.0	M16	8	18.0
	JIS 16K	200.0	160.0	154.0	M20	8	18.0
	JIS 20K	200.0	160.0	154.0	M20	8	18.0
4"	JIS 10K	210.0	175.0	162.0	M16	8	18.0
	JIS 16K	225.0	185.0	162.0	M20	8	20.0
	JIS 20K	225.0	185.0	162.0	M20	8	20.0
5"	JIS 10K	250.0	210.0	162.0	M20	8	20.0
	JIS 16K	270.0	225.0	162.0	M22	8	20.0
	JIS 20K	270.0	225.0	162.0	M22	8	20.0
6"	JIS 10K	280.0	240.0	162.0	M20	8	20.0
	JIS 16K	305.0	260.0	162.0	M22	12	20.0
	JIS 20K	305.0	260.0	162.0	M22	12	20.0
8"	JIS 10K	330.0	290.0	162.0	M20	12	22.0
	JIS 16K	350.0	305.0	162.0	M22	12	23.0
	JIS 20K	350.0	305.0	162.0	M22	12	23.0
10"	JIS 10K	400.0	355.0	200.0	M22	12	24.0
	JIS 16K	430.0	380.0	200.0	M24	12	28.0
	JIS 20K	430.0	380.0	200.0	M24	12	28.0
12"	JIS 10K	445.0	400.0	200.0	M22	16	24.0
	JIS 16K	480.0	430.0	200.0	M24	16	28.0
	JIS 20K	480.0	430.0	200.0	M24	16	28.0

DIMENSIONS

Unit:mm

SIZE	øG	øJ	L	øM	N	T	
2"	PN 10	165.0	125.0	154.0	M16	4	18.0
	PN 16	165.0	125.0	154.0	M16	4	18.0
	PN 25	165.0	125.0	154.0	M16	4	18.0
	PN 40	165.0	125.0	154.0	M16	4	18.0
2-1/2"	PN 10	185.0	145.0	154.0	M16	4	18.0
	PN 16	185.0	145.0	154.0	M16	4	18.0
	PN 25	185.0	145.0	154.0	M16	8	18.0
	PN 40	185.0	145.0	154.0	M16	8	18.0
3"	PN 10	200.0	160.0	154.0	M16	8	18.0
	PN 16	200.0	160.0	154.0	M16	8	18.0
	PN 25	200.0	160.0	154.0	M16	8	18.0
	PN 40	200.0	160.0	154.0	M16	8	18.0
4"	PN 10	220.0	180.0	162.0	M16	8	20.0
	PN 16	220.0	180.0	162.0	M16	8	20.0
	PN 25	235.0	190.0	162.0	M20	8	20.0
	PN 40	235.0	190.0	162.0	M20	8	20.0
5"	PN 10	250.0	210.0	162.0	M16	8	22.0
	PN 16	250.0	210.0	162.0	M16	8	22.0
	PN 25	270.0	220.0	162.0	M24	8	22.0
	PN 40	270.0	220.0	162.0	M24	8	22.0
6"	PN 10	285.0	240.0	162.0	M20	8	22.0
	PN 16	285.0	240.0	162.0	M20	8	22.0
	PN 25	300.0	250.0	162.0	M24	8	22.0
	PN 40	300.0	250.0	162.0	M24	8	22.0
8"	PN 10	340.0	295.0	162.0	M20	8	24.0
	PN 16	340.0	295.0	162.0	M20	12	24.0
	PN 25	360.0	310.0	162.0	M24	12	24.0
	PN 40	375.0	320.0	162.0	M27	12	24.0
10"	PN 10	395.0	350.0	200.0	M20	12	26.0
	PN 16	405.0	355.0	200.0	M24	12	26.0
	PN 10	425.0	370.0	200.0	M27	12	26.0
	PN 40	450.0	385.0	200.0	M30	12	26.0
12"	PN 10	445.0	400.0	200.0	M20	12	28.0
	PN 16	460.0	410.0	200.0	M24	12	28.0
	PN 10	485.0	430.0	200.0	M27	16	28.0
	PN 40	515.0	450.0	200.0	M30	16	28.0



A Quality Brand



Industries

1. Marine
2. Chemical
3. Petrochemical
4. Oil / Gas
5. Offshore

Fluids

1. Fluid
2. Oil
3. Chemical
4. Gas
5. Steam
6. Water