

Lug Type



Technical Data

General Product Information

Description	: GVC lug type bonded vulcanised liner butterfly valve with centric disc
Design Code	: EN 593 - 2004
Size Range	: DN 50 - DN 1000 (Larger sizes on request)
Pressure Classes	: DIN PN10, DIN PN 16 and ANSI/ASME 150
Pressure & Temp.	: DIN PN 10 = 10 barg NBR = -10 to +90°C DIN PN 16 = 16 barg EPDM = -30 to +130°C ANSI 150 = 19 barg FPM = -10 to +200°C
Operation	: ISO 5211 top flange for direct mount of; <ul style="list-style-type: none">• Hand lever• Gearbox• Pneumatic actuator• Electric actuator• Hydraulic actuator



Lug Type
Series 140

Design

Process Connections:	Suitable for mounting between flanges acc. to EN 1092 - PN 10/16, ASME B16.5 - 150
Face to Face	: EN 558 Basic series 20 ISO 5752 Basic series 20 API 609 Table 1 (Category A Valves)
Liner	: Elastomeric bonded liner vulcanized to body Non-collapsible Non-replaceable Bi-directional tight shut-off
Shaft Seal Design	: Primary and secondary shaft seal system within liner
Shaft	: DN 50-DN 300 with 2-pc shaft construction DN > DN 300 with 1-pc shaft construction
Bearings	: Bearings vulcanized to liner

Valve Testing

Valves have been tested and found acceptable in compliance with the following standards

Shell strength	: Test P10 - EN 12266-1 API 598
Shell tightness	: Test P11 - EN 12266-1 API 598
Seat tightness	: Test P12 - EN 12266-1 Rate A API 598
Operability	: Test F20 - EN 12266-2
Anti static design	: Test F21 - EN 12266-2

Additional information

- Suitable for vacuum applications
- Suitable for end of line service
- On-Off and throttling / regulating applications
- Suitable for high velocity applications up to;
 - 4 m/sec. for liquids
 - 30 m/sec. for gasses
- Marking EN 19 - 2002
- Material and Test certification, EN 10204 - 2.2, 3.1 and 3.2
- Special coating systems available (Off-shore coating etc.)



The Bonded Liner Concept

Top and Bottom Shaft

- DN ≤ 300 2 piece system
- DN > 300 1 piece system
- High accuracy polished material
- ISO fit system
- High strength stainless steel
- Square shaft end with position indication
- Available in various materials

Additional Support

- Preventing shaft distortion and ensuring low torque values
- Preventing foreign matter from entering the valve

Top and Bottom Bearings

- Tin Bronze high accuracy bearings
- Vulcanized to liner
- Self lubricating
- ISO fit system
- Perfect alignment of valve shaft

EN ISO 5211 Top Flange for Direct Mount of

- Hand levers
- Gear boxes
- Pneumatic actuators
- Electric actuators
- Hydraulic actuators

Precision Pin(s)

- High accuracy polished pin(s)
- Press fitted in a blind hole, no leakage over pin
- Vibration proof
- Shaft to disc connection
- Available in various materials

Body

- Standard EN JS1030 Nodular Cast Iron body, painted in RAL 7036 (60 µm 2 layer coating)
- Certified material from Maritime classification society approved foundries
- Extreme High Strength body, during vulcanization body is exposed to internal pressures of up to 100 barg
- Threaded lug holes (UNC/Metric)
- End of line service
- Easy to mount, mount and forget
- Available in various materials

Disc

- Streamlined disc for low pressure loss in fully open position
- Precision machined
- Bubble tight shut off
- Low torque

Bonded Liner

- High accuracy bonded liner fully vulcanized to body
- Vulcanization in precision machined transfer molding tools
- Repeatable accurate liner dimensions
- Reliable low torque figures
- No corrosion between liner and body
- No flange gasket required
- No rolling up of liner
- Long life liner
- Non collapsible, stretch resistant, blow out proof liner
- Suitable for end of line service
- Suitable for vacuum and high fluid velocity applications
- Suitable for dry service
- Available in various materials

Shaft Sealing System

- Top and bottom shaft sealing with primary and secondary sealing system

Plug and Gasket

- Bottom shaft support
- Safety sealing system

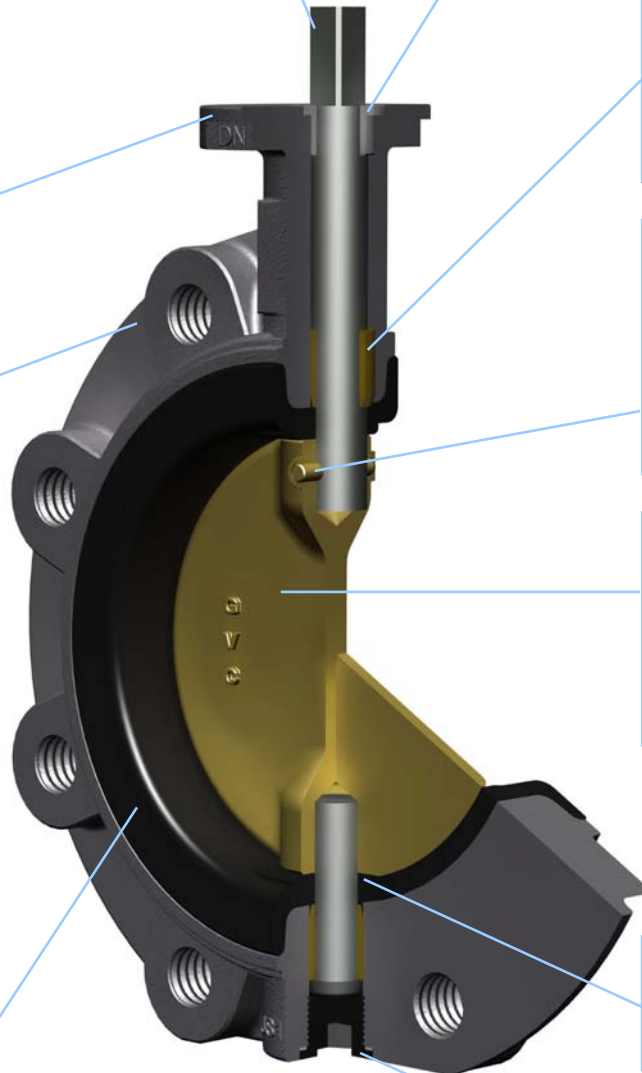

The “Long Life Butterfly Valve”

Materials

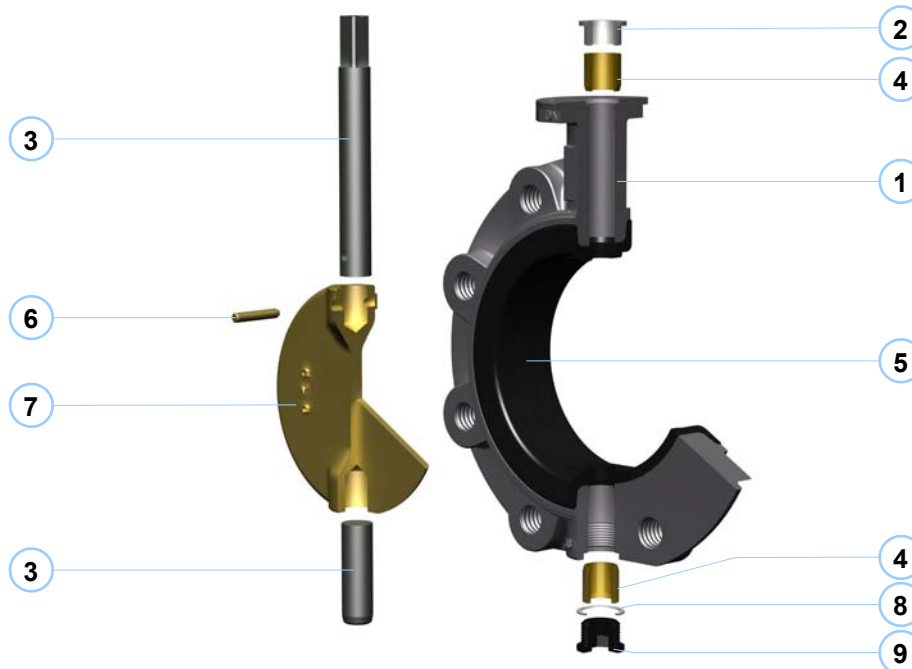

No	Part	Material	Name	Number	Standard	Former	W. Nr.	Note
1	Body	Nodular Cast Iron	EN-GJS-400-15	JS1030	EN 1563	GGG-40	0.7040	A+B
		Cast Steel	A216 Grade WCB		ASTM A216		1.0619	C
		Cast Stainless Steel	A351 Grade CF8M		ASTM A351		1.4408	C
		Cast Aluminium Bronze	CuAl10Fe5Ni5-C	CC333G	EN 1982	BS 1400-AB2	2.0976	C
		Cast Low Zinc Bronze	G-CuSn10Zn		DIN 1705	Rg10	2.1086	C
2	Support	Polyamide	PA66					A+B
3	Shaft	Stainless Steel	X39CrMo 17-1		EN 10088	X35CrMo17	1.4122	A+B
		Duplex Stainless Steel	X2CrNiMoN22-5-3		ASTM A276		1.4462	C
		Monel K500®	NA 18		BS 3076			C
		Aluminium Bronze	UNS C 63000		ASTM B150		2.0966	C
4	Bearing	Bronze	CuSn7ZnPb	CC493K	EN 1982		2.1090	A+B
5	Liner	Elastomeric	NBR					A
			EPDM					B
			FPM					C
6	Pin	Stainless Steel	X39CrMo 17-1		EN 10088	X35CrMo17	1.4122	C
		Stainless Steel	X2CrNiMo17-12-2		EN 10088		1.4404	B
		Monel K500®	NA 18		BS 3076			C
		Aluminium Bronze	UNS C 63000		ASTM B150		2.0966	A
7	Disc	Nodular Cast Iron (Rilsan)	EN-GJS-400-15	JS1030	EN 1563	GGG-40	0.7040	C
		Aluminium Bronze	CuAl10Fe5Ni5-C	CC333G	EN 1982	BS 1400-AB2		A
		Stainless Steel	A743 Grade CF8M		ASTM A743		1.4408	B
		Duplex Stainless Steel	X2CrNiMoN22-5-3		ASTM A276		1.4462	C
		Monel K400®	A494 M35		ASTM A494			C
8	Gasket	Non asbestos						A+B
9	Plug	Galvanized Steel						A+B

A = Standard stock material combination (for Marine applications)
B = Standard stock material combination (for General Industry applications)
C = Upon request

Other materials on request

Dimensions DN 50 - 1000 (PN 10)

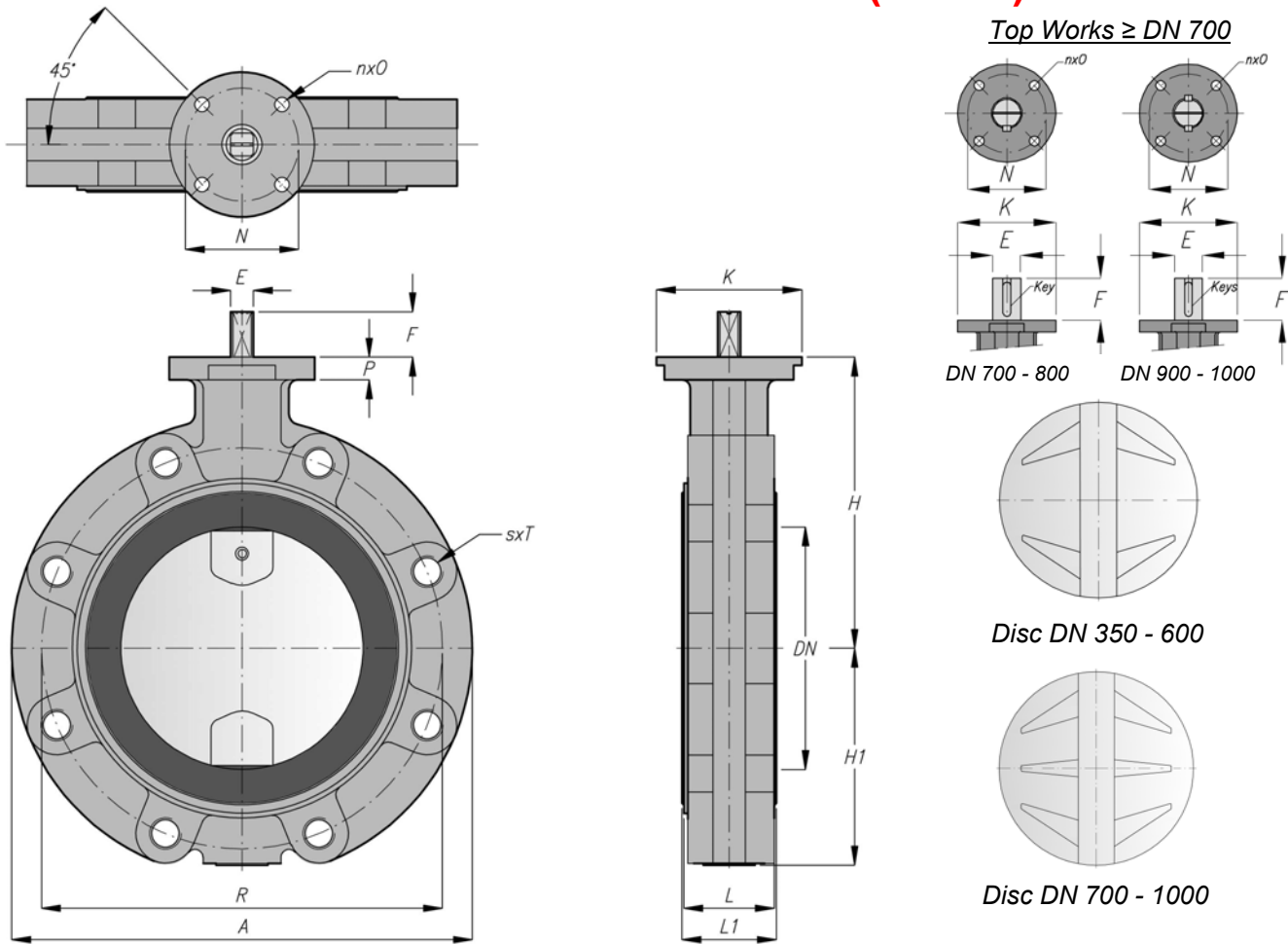

Dimensions DN 50 - 1000, **DIN PN10** [mm]

DN	øA	□E	øE	Key(s)	F	H	H1	øK	L	L1	N	ISO	nxO	P	R	s x T	Weight	
50	165	10	--	--	--	25	118	67	90	43	44.8	70	F07	4xø9	12	125	4 x M16	3.8 Kg
65	185	10	--	--	--	25	126	74	90	46	47.8	70	F07	4xø9	12	145	4 x M16	4.8 Kg
80	195	10	--	--	--	25	133	82	90	46	47.8	70	F07	4xø9	14	160	8 x M16	5.4 Kg
100	224	12	--	--	--	25	147	100	90	52	54.0	70	F07	4xø9	14	180	8 x M16	8.3 Kg
125	254	12	--	--	--	25	160	112	90	56	58.2	70	F07	4xø9	14	210	8 x M16	10.3 Kg
150	285	16	--	--	--	25	180	134	90	56	58.4	70	F07	4xø9	14	240	8 x M20	12.9 Kg
200	337	16	--	--	--	25	204	159	90	60	63.0	70	F07	4xø9	14	295	8 x M20	18.3 Kg
250	405	24	--	--	--	30	245	195	125	68	71.0	102	F10	4xø11	15	350	12 x M20	30.1 Kg
300	472	24	--	--	--	30	270	220	125	78	81.2	102	F10	4xø11	15	400	12 x M20	45.9 Kg
350	520	27	--	--	--	29	315	282	150	78	81.4	125	F12	4xø14	20	460	16 x M20	57.5 Kg
400	597	27	--	--	--	29	350	307	150	102	105.6	125	F12	4xø14	20	515	16 x M24	96.5 Kg
450	640	36	--	--	--	38	375	352	175	114	117.8	140	F14	4xø18	20	565	20 x M24	On request
500	710	36	--	--	--	38	415	387	175	127	131.0	140	F14	4xø18	20	620	20 x M24 x 36	On request
600	780	46	--	--	--	48	465	452	210	154	158.2	165	F16	4xø22	25	725	20 x M27 x 40	On request
700	805	--	70	1 pc	20x12x100	110	555	485	210	165	169.4	165	F16	4xø22	25	840	24 x M27 x 41	On request
800	910	--	80	1 pc	22x14x110	120	620	555	300	190	194.6	254	F25	8xø18	30	950	24 x M30 x 45	On request
900	1010	--	90	2 pcs	25x14x110	120	660	625	300	203	207.8	254	F25	8xø18	30	1050	28 x M30 x 45	On request
1000	1110	--	90	2 pcs	25x14x110	120	725	680	300	216	221.0	254	F25	8xø18	30	1160	28 x M33 x 50	On request

Dimensions DN 50 - 1000 (PN 16)

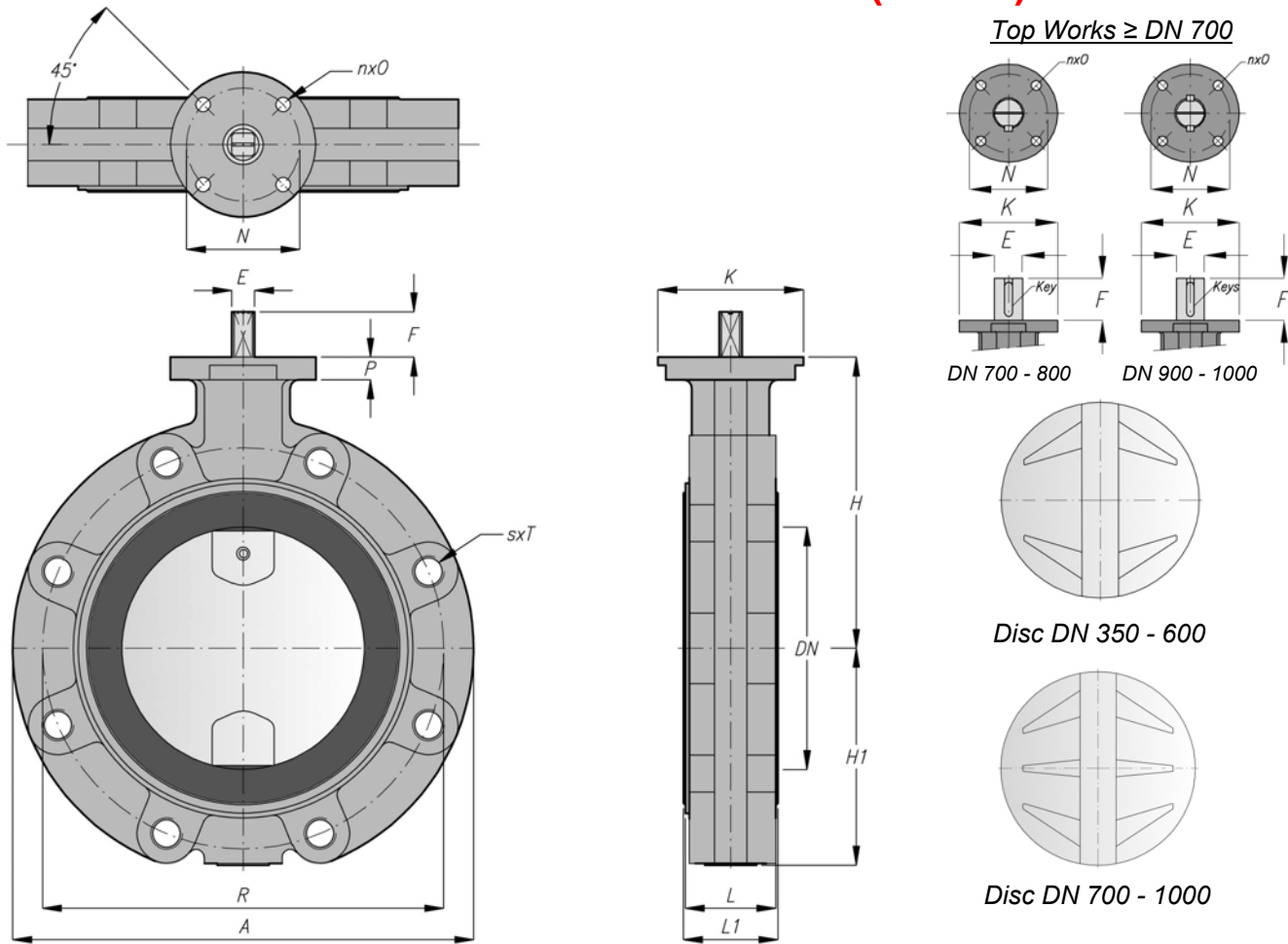

Dimensions DN 50 - 1000, **DIN PN16** [mm]

DN	øA	□E	øE	Key(s)	F	H	H1	øK	L	L1	N	ISO	nxO	P	R	s x T	Weight	
50	165	10	--	--	--	25	118	67	90	43	44.8	70	F07	4xø9	12	125	4 x M16	3.8 Kg
65	185	10	--	--	--	25	126	74	90	46	47.8	70	F07	4xø9	12	145	4 x M16	4.8 Kg
80	195	10	--	--	--	25	133	82	90	46	47.8	70	F07	4xø9	14	160	8 x M16	5.4 Kg
100	224	12	--	--	--	25	147	100	90	52	54.0	70	F07	4xø9	14	180	8 x M16	8.3 Kg
125	254	12	--	--	--	25	160	112	90	56	58.2	70	F07	4xø9	14	210	8 x M16	10.3 Kg
150	285	16	--	--	--	25	180	134	90	56	58.4	70	F07	4xø9	14	240	8 x M20	12.9 Kg
200	337	16	--	--	--	25	204	159	90	60	63.0	70	F07	4xø9	14	295	12 x M20	18.3 Kg
250	405	24	--	--	--	30	245	195	125	68	71.0	102	F10	4xø11	15	355	12 x M24	30.1 Kg
300	472	24	--	--	--	30	270	220	125	78	81.2	102	F10	4xø11	15	410	12 x M24	45.9 Kg
350	520	27	--	--	--	29	315	282	150	78	81.4	125	F12	4xø14	20	470	16 x M24	57.5 Kg
400	597	27	--	--	--	29	350	307	150	102	105.6	125	F12	4xø14	20	525	16 x M27	96.5 Kg
450	640	36	--	--	--	38	375	352	175	114	117.8	140	F14	4xø18	20	585	20 x M27	On request
500	710	36	--	--	--	38	415	387	175	127	131.0	140	F14	4xø18	20	650	20 x M30 x 45	On request
600	780	46	--	--	--	48	465	452	210	154	158.2	165	F16	4xø22	25	770	20 x M33 x 47	On request
700	805	--	80	1 pc	22x14x110	120	555	505	210	165	169.4	165	F16	4xø22	25	840	24 x M33 x 50	On request
800	900	--	100	1 pc	28x16x110	120	615	575	300	190	194.6	254	F25	8xø18	30	950	24 x M36 x 54	On request
900	1010	--	110	2 pcs	32x16x140	160	675	645	300	203	207.8	254	F25	8xø18	30	1050	28 x M36 x 54	On request
1000	1110	--	120	2 pcs	32x18x140	160	750	695	300	216	221.0	254	F25	8xø18	30	1170	28 x M39 x 59	On request

Dimensions DN 50 - 1000 (ANSI 150)

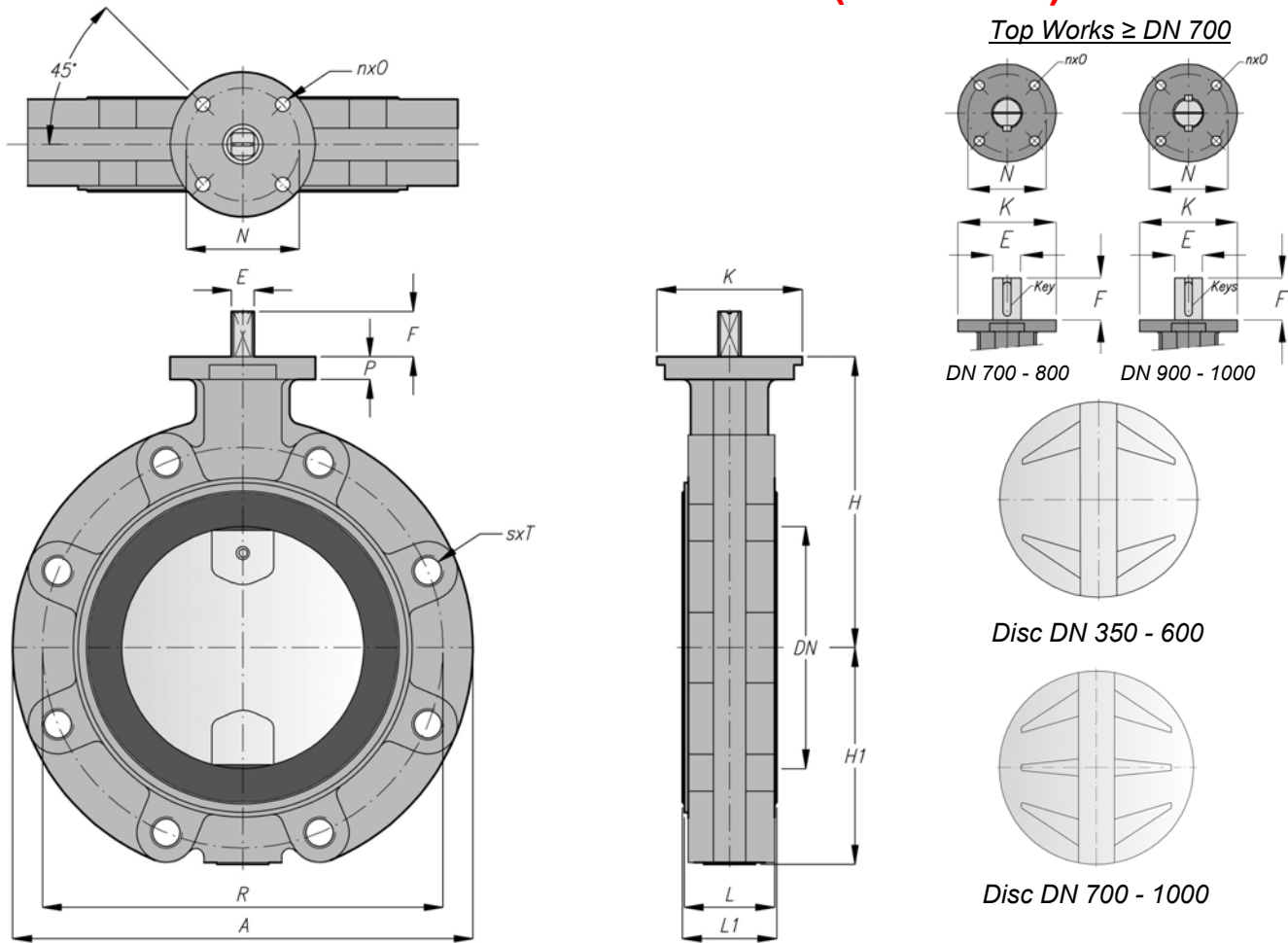

Dimensions DN 50 - 1000, ANSI 150

DN	øA	□E	øE	Key(s)	F	H	H1	øK	L	L1	N	ISO	nxO	P	R	s x T	Weight	
50	165	10	--	--	25	118	67	90	43	44.8	70	F07	4xø9	12	120.6	4x5/8"UNC	3.8 Kg	
65	185	10	--	--	25	126	74	90	46	47.8	70	F07	4xø9	12	139.7	4x5/8"UNC	4.8 Kg	
80	195	10	--	--	25	133	82	90	46	47.8	70	F07	4xø9	14	152.4	4x5/8"UNC	5.4 Kg	
100	224	12	--	--	25	147	100	90	52	54.0	70	F07	4xø9	14	190.5	8x5/8"UNC	8.3 Kg	
125	254	12	--	--	25	160	112	90	56	58.2	70	F07	4xø9	14	215.9	8x3/4"UNC	10.3 Kg	
150	285	16	--	--	25	180	134	90	56	58.4	70	F07	4xø9	14	241.3	8x3/4"UNC	12.9 Kg	
200	337	16	--	--	25	204	159	90	60	63.0	70	F07	4xø9	14	298.4	8x3/4"UNC	18.3 Kg	
250	405	24	--	--	30	245	195	125	68	71.0	102	F10	4xø11	15	361.9	12x7/8"UNC	30.1 Kg	
300	472	24	--	--	30	270	220	125	78	81.2	102	F10	4xø11	15	431.8	12x7/8"UNC	45.9 Kg	
350	520	27	--	--	29	315	282	150	78	81.4	125	F12	4xø14	20	476.2	12x1"UNC	57.5 Kg	
400	597	27	--	--	29	350	307	150	102	105.6	125	F12	4xø14	20	539.7	12x1"UNC	96.5 Kg	
450	640	36	--	--	38	375	352	175	114	117.8	140	F14	4xø18	20	577.8	12x1½"UNC	On request	
500	710	36	--	--	38	415	387	175	127	131.0	140	F14	4xø18	20	635.0	20x1½"UNCx47	On request	
600	780	46	--	--	48	465	452	210	154	158.2	165	F16	4xø22	25	749.3	20x1¼"UNCx47	On request	
700*	805	--	70	1 pc	20x12x100	110	555	485	210	165	169.4	165	F16	4xø22	25	863.6	28x1¼"UNCx48	On request
800*	900	--	80	1 pc	22x14x110	120	620	555	300	190	194.6	254	F25	8xø18	30	977.9	28x1½"UNCx57	On request
900*	1010	--	90	2 pcs	25x14x110	120	660	625	300	203	207.8	254	F25	8xø18	30	1086	32x1½"UNCx57	On request
1000*	1110	--	90	2 pcs	25x14x110	120	725	680	300	216	221.0	254	F25	8xø18	30	1200	36x1½"UNCx57	On request

* Maximum working pressure for DN 700 - DN1000 is 10 barg

“Everything You Need to Size”

Torque Figures

Torque

Torque figures as mentioned in the torque table are;

- Initial break away values in Nm (Newton Meters)
- **Excluding** any safety factor
- For valves that are operated at least once per month
- Temperature 0° to 50°C

Safety factor (sf)

For sizing and safe operation purposes the specified torque values need to be multiplied with the following minimum safety factors;

- For liquid and lubricant media **sf = 1.20**
- For powdery (non-lubricant) media **sf = 1.55**
- For dry gasses and high viscous media **sf = 1.45**

Service

For assistance in sizing and dimensioning actuators-valve combinations please contact our Engineers. We have wide experience in sizing Pneumatic, Electric and Hydraulic actuators.

DN	PN 10			PN 16			
	ΔP 2.5 bar	ΔP 6.0 bar	ΔP 10 bar	ΔP 2.5 bar	ΔP 6.0 bar	ΔP 10 bar	ΔP 16 bar
50	--	--	--	6.9	7.6	9.9	13.0
65	--	--	--	9.9	10.7	13.0	14.5
80	--	--	--	13.0	15.2	18.3	22.8
100	--	--	--	21.3	16.0	22.8	28.9
125	--	--	--	29.7	30.4	38.0	53.2
150	--	--	--	45.6	53.2	62.4	83.6
200	--	--	--	91.2	106.4	121.6	144.4
250	144.5	167.5	190.0	228.0	243.5	213.0	281.5
300	205.5	236.0	266.0	319.5	342.0	312.0	395.5
350	236.0	274.0	312.0	365.0	403.0	410.5	593.0
400	350.0	410.5	486.5	532.0	593.0	585.5	851.5
450	479.0	562.5	646.0	730.0	836.0	828.5	1087.0
500	638.5	737.5	836.0	988.0	1064.0	1102.5	1368.0
600	1064.0	1216.0	1444.0	1596.0	1824.0	2052.0	2356.0
700	1824.0	2128.0	2432.0	2812.0	3116.0	2736.0	3952.0
800	2508.0	2888.0	3344.0	3800.0	4180.0	3785.0	5320.0
900	3420.0	4104.0	4864.0	5168.0	5852.0	5108.0	7600.0
1000	4408.0	5244.0	6156.0	6688.0	7524.0	7752.0	9880.0

Sizing Dimensions

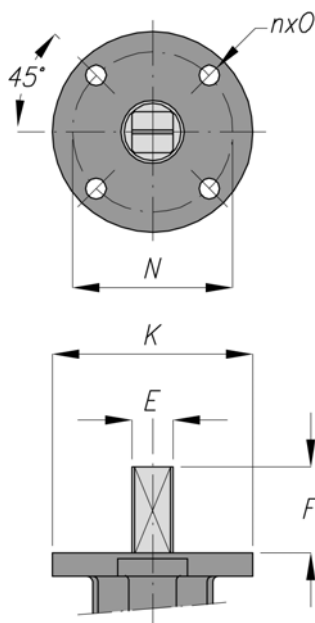

DN	E	F	ϕK	N	ISO	nxO
50	$\square 10$	25	90	70	F07	4 x $\phi 9$
65	$\square 10$	25	90	70	F07	4 x $\phi 9$
80	$\square 10$	25	90	70	F07	4 x $\phi 9$
100	$\square 12$	25	90	70	F07	4 x $\phi 9$
125	$\square 12$	25	90	70	F07	4 x $\phi 9$
150	$\square 16$	25	90	70	F07	4 x $\phi 9$
200	$\square 16$	25	90	70	F07	4 x $\phi 9$
250	$\square 24$	30	125	102	F10	4 x $\phi 12$
300	$\square 24$	30	125	102	F10	4 x $\phi 12$
350	$\square 27$	29	150	125	F12	4 x $\phi 14$
400	$\square 27$	29	150	125	F12	4 x $\phi 14$
450	$\square 36$	38	175	140	F14	4 x $\phi 18$
500	$\square 36$	38	175	140	F14	4 x $\phi 18$
600	$\square 46$	48	210	165	F16	4 x $\phi 22$
700	DN 700 - DN 1000 butterfly valves have cylindrical stems with key(s), dimensions depend on the applicable pressure class. Please check the dimensions table in this brochure.					
800						
900						
1000						

KV Values

Opening Angle Disc								
DN	20°	30°	40°	50°	60°	70°	80°	90°
50	0.88	3.37	13.8	34.6	56.3	87.0	125	170
65	1.46	5.35	22	55	90	138	198	270
80	2.47	10.2	40.4	102	167	256	368	505
100	4.05	16.1	63.4	159	263	406	581	795
125	7.15	29.8	117	293	481	744	1064	1460
150	10.5	41.9	167	418	691	1068	1529	2095
200	21.0	81.8	329	822	1367	2096	3000	4110
250	25.6	101	402	1005	1658	2563	3669	5025
300	34.9	140	559	1394	2302	3558	5092	6975
350	42.4	152	678	1516	2501	3866	5533	7580
400	55.2	201	885	2008	3313	5119	7329	10040
450	70.6	257	1118	2568	4237	6548	9372	12840
500	86.3	320	1380	3197	5275	8152	11669	15985
600	124	466	1986	4663	7694	11891	17067	23315
700	157	891	2528	6321	10429	16118	23071	31605
800	194	774	3096	7740	12771	19737	28251	38700
900	259	1038	4828	10380	17127	26469	37844	51901
1000	324	1295	5179	12948	21365	33018	47261	64742

KV-values

KV values as mentioned in the KV-Value Table are;

- German KV values (m³/hour water of 20°C at a ΔP of 1 bar over the valve)
- Maximum allowable flow velocities;
 - 4 m/sec. for liquids
 - 30 m/sec. for gasses
- Make sure there is no cavitation

Calculations

Pressure drop (P1-P2) and/or flow (Q) calculations can be performed using the formula's below.

You can calculate pressure drop and/or flow with a fully opened disc when the valve is used in on-off applications or you can calculate the pressure drop and/or flow in above intermediate disc positions when the valve is used in throttling and regulating applications.

For Liquids:

$$KV = Q \cdot \sqrt{\frac{\rho / \rho_0}{P_1 - P_2}}$$

For Gasses (Where P1 < 2 · P2):

$$KV = \frac{Q}{457} \cdot \sqrt{\frac{G \cdot T_i}{(P_1 - P_2) P_1}}$$

Where

Q	=	Flow	[m ³ /hr]
ρ	=	Specific Gravity	[Kg/m ³]
ρ ₀	=	Specific Gravity of water under standard conditions	(ρ ₀ = 1000 kg/m ³ at 288K)
P ₁	=	Inlet Pressure	[Barg]
P ₂	=	Outlet Pressure	[Barg]
G	=	Relative Specific Gravity in relation to air (G = ρ / ρ _{air})	under standard conditions
T _i	=	Inlet Temperature	[K]

Service

For assistance on pressure drop calculations and other belonging matters please contact our Engineers.

The GVC Bonded Liner Valve Range

Series 110



Wafer

- DN 40-1000
- DIN PN 10/16/25
- ANSI 150

Series 140



Lug

- DN 50-1000
- DIN PN 10/16
- ANSI 150

Series 120



Mono Short

- DN 50-400
- DIN PN 10/16
- ANSI 150

Series 150



Flanged

- DN 50-1000
- DIN PN 10/16
- ANSI 150

Series 130



Mono Long

- DN 50-400
- DIN PN 10/16
- ANSI 150



Global Valve Center B.V.
Boelewerf 14
2987 VD Ridderkerk
The Netherlands

Tel 1 +31 (0) 180 39 89 38
Tel 2 +31 (0) 180 39 88 69
Fax +31 (0) 84 22 98 163
E-mail info@globalvalvecenter.com
Internet www.globalvalvecenter.com

THE VALVE SPECIALIST